

# WORLD CLASS PRODUCTIVITY — NIIGATA MODEL D

NIIGATA's world famous and highly regarded horizontal machining center Model D is now fully reengineered as "A World Class Machining Center."

The Model D is the result of NIIGATA's constant research and development for profitable machining of large components. Key development criteria for the "D" series were: larger capacity, higher productivity, and increased accuracies. NIIGATA, a world leader of horizontal machining centers, is proud to declare that the model D, a new design achieving significant performance advances, will satisfy all requirements of your production needs.

## LARGEST WORK ENVELOPE IN ITS CLASS

Niigata is known for large envelopes in each model. Consider the travel and work piece size below.

Many parts, which previously required one size larger machine, now will fit on this Niigata work-horse.

The upgraded capacity offers superior price/performance and quicker ROI.

### HN80D

|        |        |                |
|--------|--------|----------------|
| TRAVEL | X axis | 1530mm (60.2") |
|        | Y axis | 1230mm (48.4") |
|        | Z axis | 1020mm (40.2") |

|                               |                |
|-------------------------------|----------------|
| Max Work piece Swing Diameter | 1750mm (68.9") |
|-------------------------------|----------------|

|        |                |
|--------|----------------|
| Height | 1400mm (55.1") |
|--------|----------------|

### HN100D

|        |        |                |
|--------|--------|----------------|
| TRAVEL | X axis | 2030mm (79.9") |
|        | Y axis | 1650mm (65.0") |
|        | Z axis | 1200mm (47.2") |

|                               |                |
|-------------------------------|----------------|
| Max Work piece Swing Diameter | 2300mm (90.6") |
|-------------------------------|----------------|

|        |                |
|--------|----------------|
| Height | 1850mm (72.8") |
|--------|----------------|

## LARGEST WORK HEAVY DUTY MACHINE RIGIDITY

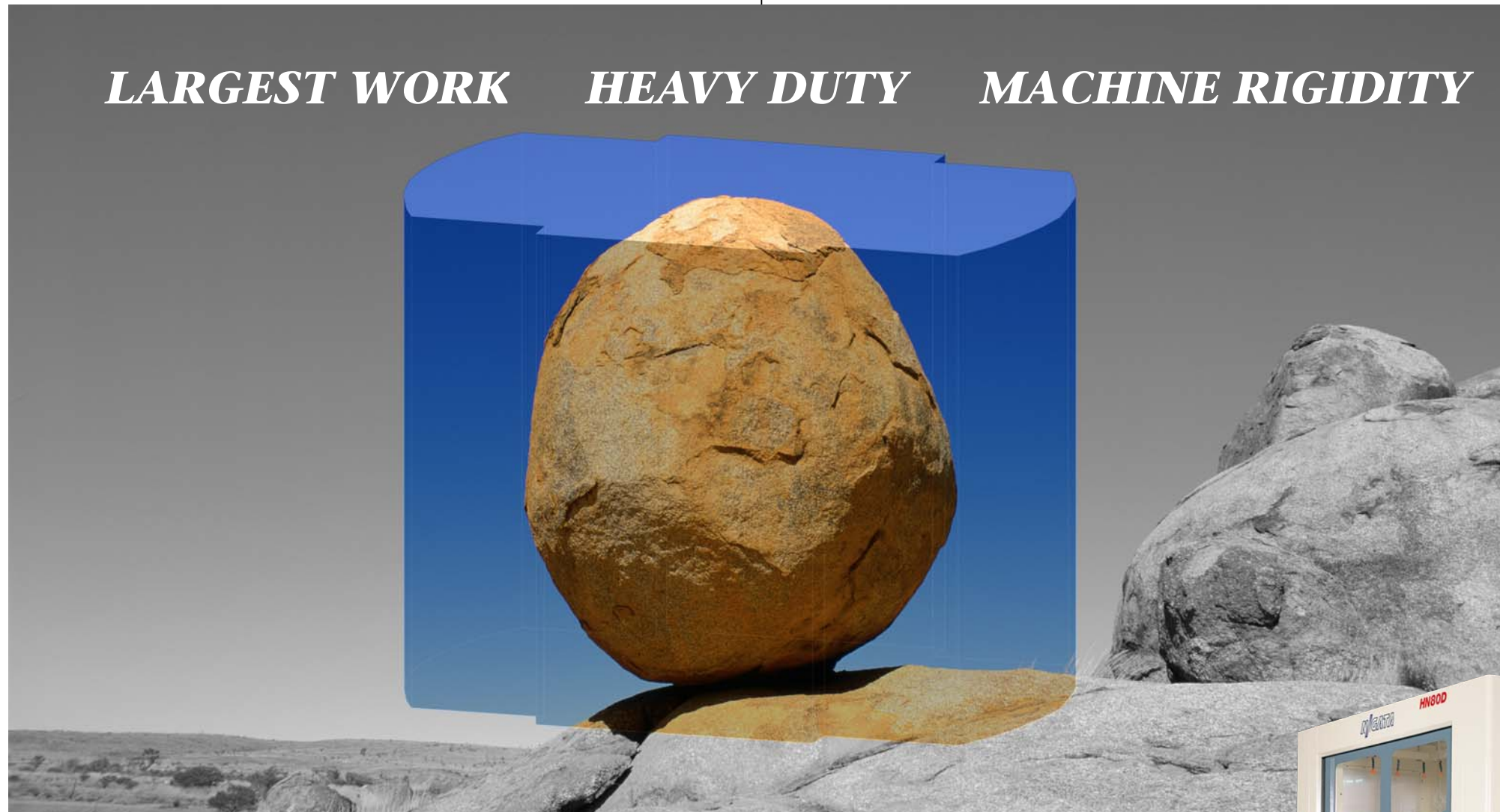

## HEAVY DUTY BOXWAY STYLE MACHINE CONSTRUCTION

As Niigata's tradition, guide ways are a combination of hardened and ground ways and hand-scraped turcite ways that provide superior stability and vibration dampening characteristics as well as a long life-cycle. The cross section of the rectangular guide ways are thick and wide for maximum machine rigidity.

## HIGH OUTPUT SOLUTION

High horse power and torque allow you to take full advantage of the rigid machine frame.

Chip removal in steel (S50C) is: 1600cm<sup>3</sup>/min (99 cu.inch)

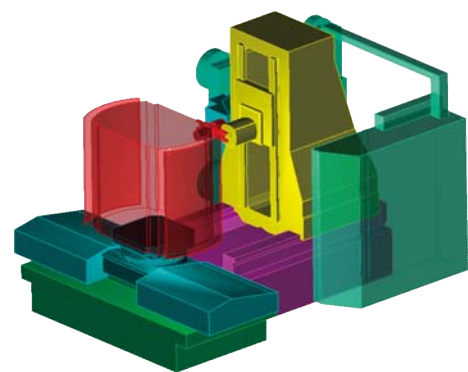

### CONTENTS

|  |         |
|--|---------|
| WORLD CLASS PRODUCTIVITY — NIIGATA MODEL D                             | 2 — 3   |
| SOLID, WELL BALANCED COMPONENTS ACHIEVE ENHANCED PRODUCTIVITY          | 4 — 5   |
| DESIGNED AND BUILT FOR FINE PRECISION ACCURACY                         | 6 — 7   |
| DESIGN DETAILS FOCUSED ON OPERATOR FRIENDLINESS                        | 8       |
| HIGH RELIABILITY AND EASE OF MAINTENANCE                               | 9       |
| OUTSTANDING CHIP REMOVAL PROVES SUBSTANTIAL MACHINE RIGIDITY           | 10      |
| MACHINE SPECIFICATIONS   | 11      |
| MAXIMUM UTILIZATION OF VALUABLE FLOOR SPACE — HN80D                    | 12      |
| LARGEST WORK CUBE OF ANY MACHINE IN ITS CLASS — HN80D                  | 13      |
| MAXIMUM UTILIZATION OF VALUABLE FLOOR SPACE — HN100D                   | 14      |
| LARGEST WORK CUBE OF ANY MACHINE IN ITS CLASS — HN100D                 | 15      |
| WIDE RANGE OF OPTIONS TO ANSWER YOUR INDIVIDUAL MACHINING REQUIREMENTS | 16 — 17 |
| THE VERSATILE HORIZONTAL FACING CENTER MODEL HN80D-FC/HN100D-FC        | 18 — 19 |
| THE HORIZONTAL BAR CENTER MODEL HN80D-BAR/HN100D-BAR                   | 20 — 21 |



# SOLID, WELL BALANCED COMPONENTS ACHIEVE ENHANCED PRODUCTIVITY



## FULL RIB CONSTRUCTION MAXIMIZES RIGIDITY

Accuracy and heavy duty machining demand a stable massive frame to fully utilize its capability. Structural strength of each component has been maximized by thick-walled castings together with extensive use of ribs.

## STURDY TABLE DESIGN SUPPORT HEAVIER LOAD CAPACITY

HN80D: 2500kg (5500lbs)  
 HN100D: 3500kg (7700lbs) /  
 [Optional 5000kg (11000lbs)  
 On 4th axis table only]

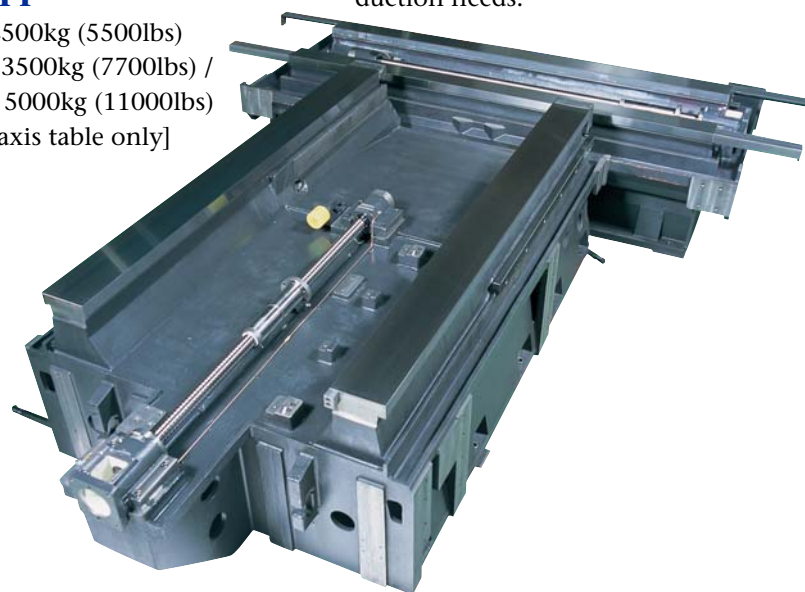

## NEWLY ENGINEERED MACHINE RIGIDITY

Niigata's reputation for superior machine rigidity and excellent cutting capability is widely accepted in the market place. All major components, such as the spindle, bed, column, and wing-base of the new HN80D/HN100D machines, have been engineered to maximize metal cutting. Solid, well-balanced components, meet a wide variety of production needs.

- 25% increase in bed thickness.
- 75% increase in span of Z axis slide ways.
- 40% increase in column rigidity.

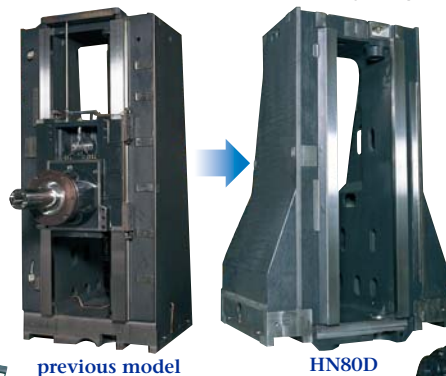

Note: These figures compare The HN80D machine to the previous HN80C model.

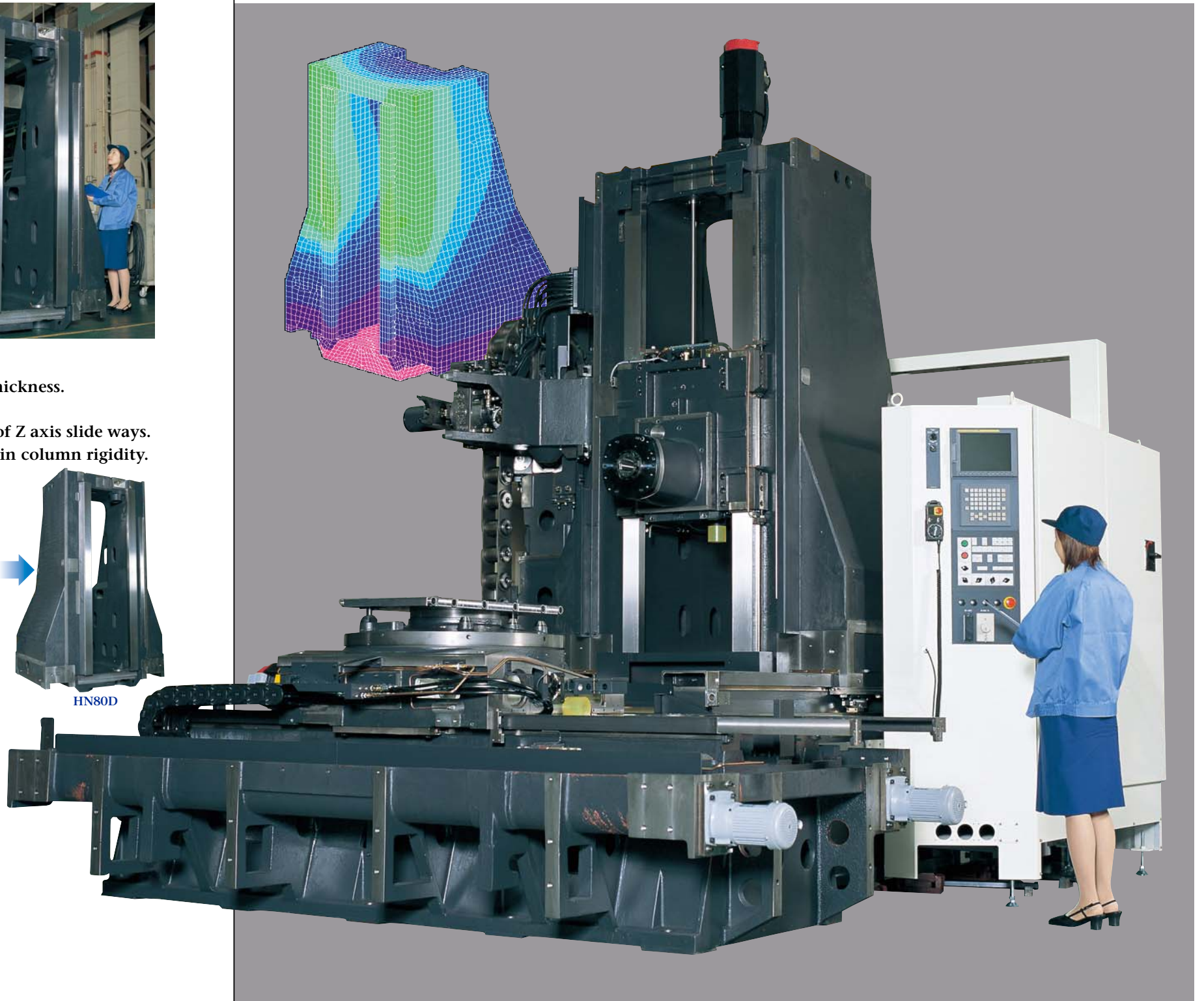

# OUTSTANDING CHIP REMOVAL PROVES SUBSTANTIAL MACHINE RIGIDITY



## HIGH TORQUE HEAVY DUTY SPINDLE

POWER: 37kW (50HP)  
TORQUE: 1200 N·m

The rugged and reliable spindle employs wide-spaced, super precision tapered roller and angular contact bearings with a 110mm (4.33") diameter (ID). The spindle head stock is a mono-cast (single piece) casting to achieve heavy and powerful milling capability and greater accuracy than bolt-together type spindle heads. This high performance spindle, power and torque complements the extremely rigid machine frame.

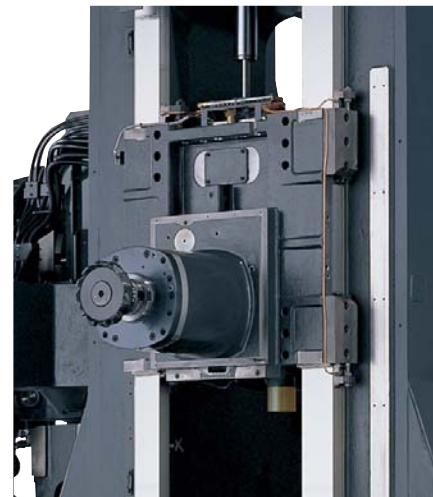

SPINDLE SPEED AND TORQUE DIAGRAM

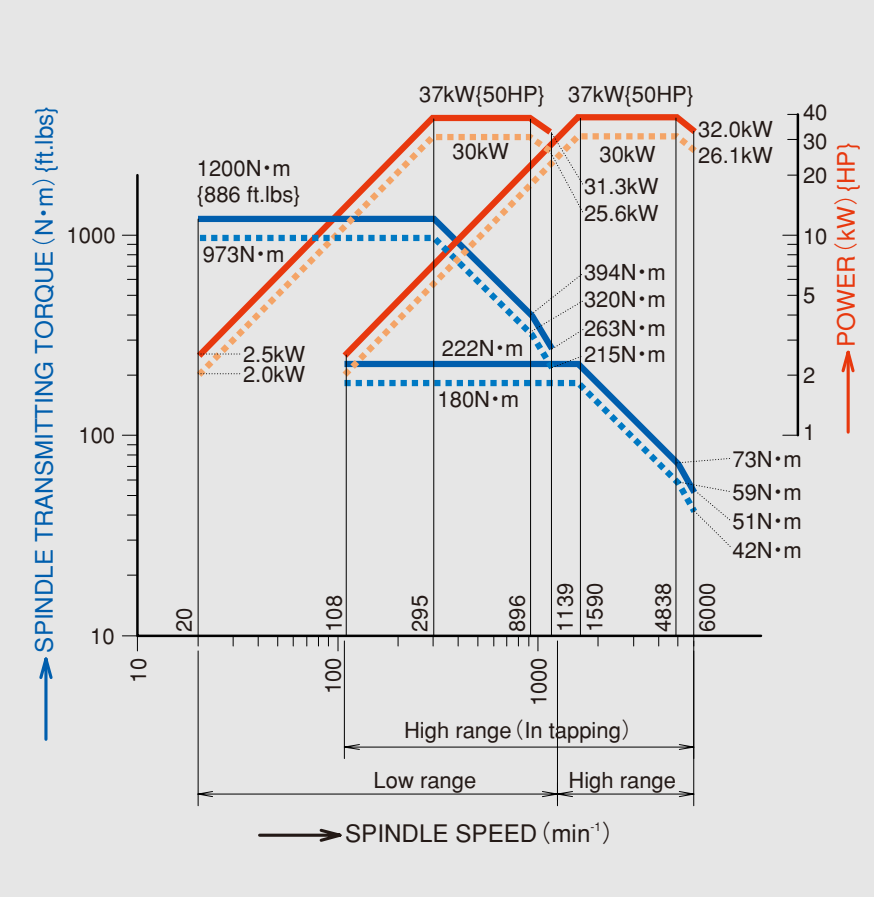

HIGH TORQUE GEARED SPINDLE

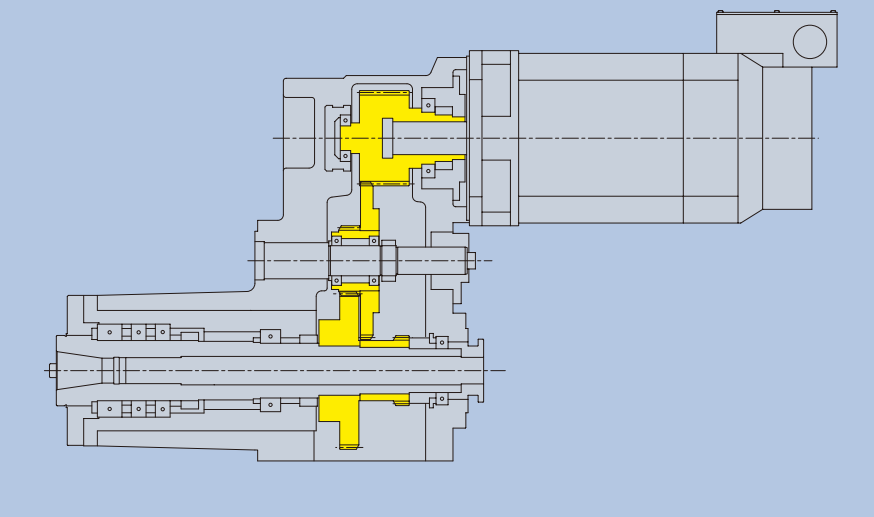

Full 37kW (50HP) cuts are achieved through an advanced (2) range head stock. With only (3) rotating components maximum power is transmitted simply and efficiency to the cutting tool.

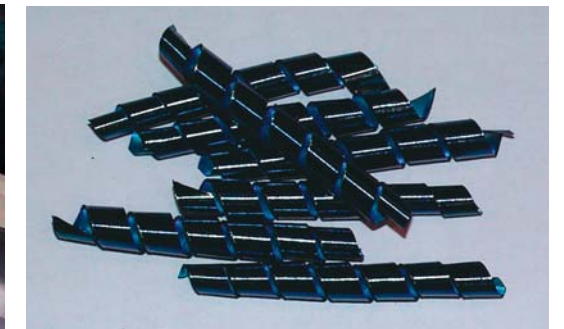
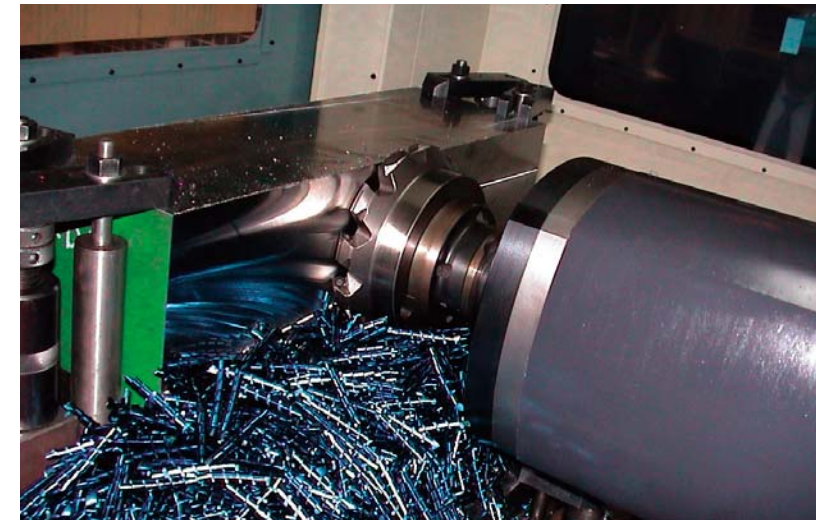

## EXAMPLE OF HN80D's MACHINING PERFORMANCE

### •Milling cutter

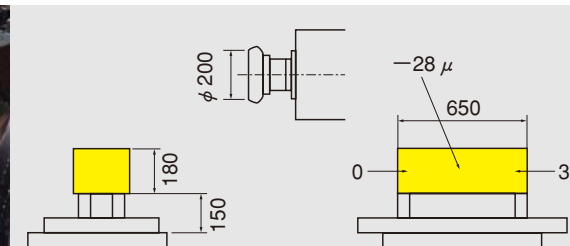

- Material : SKD61(Hardness HRC45)
- Tool : φ 200-12T Milling Cutter
- Depth of Cut : 5mm
- Spindle Speed : 127min<sup>-1</sup>(127rpm)
- Cutting Speed : 80m/min

### •Milling cutter

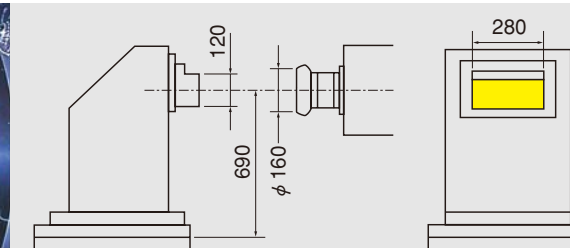

- Material : S50C
- Tool : φ 160-8T Milling Cutter
- Depth of Cut : 7mm
- Spindle Speed : 500min<sup>-1</sup>(500rpm)
- Cutting Speed : 251m/min

### •Indexable Drill

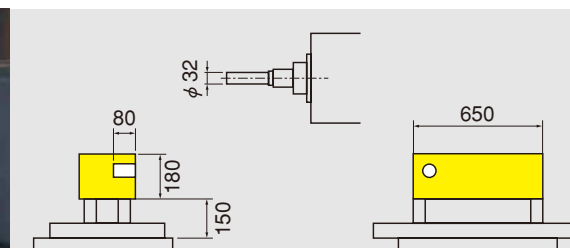

- Material : SKD61(Hardness HRC45)
- Tool : φ 32 Indexable Drill
- Spindle Speed : 796min<sup>-1</sup>(796rpm)
- Cutting Speed : 80m/min

# DESIGNED AND BUILT FOR FINE PRECISION ACCURACY

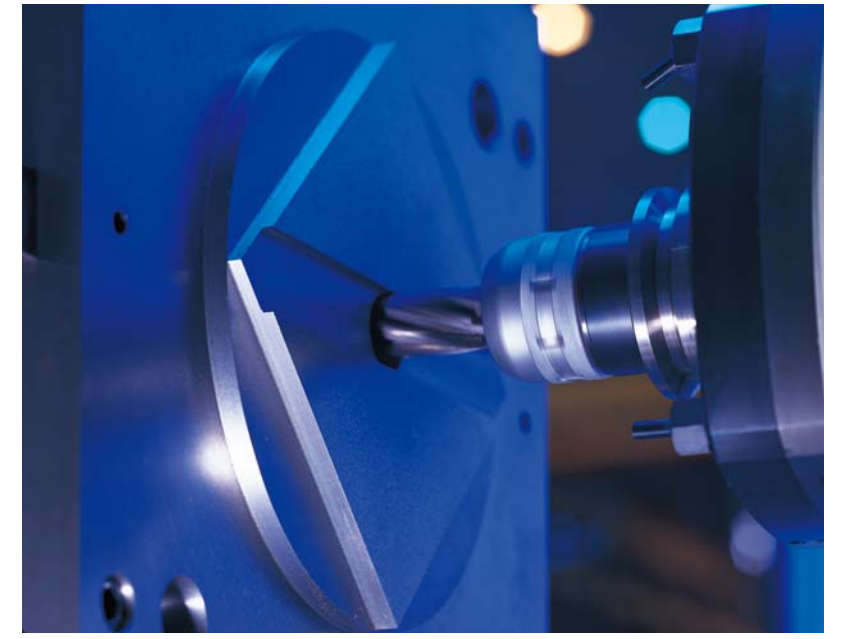
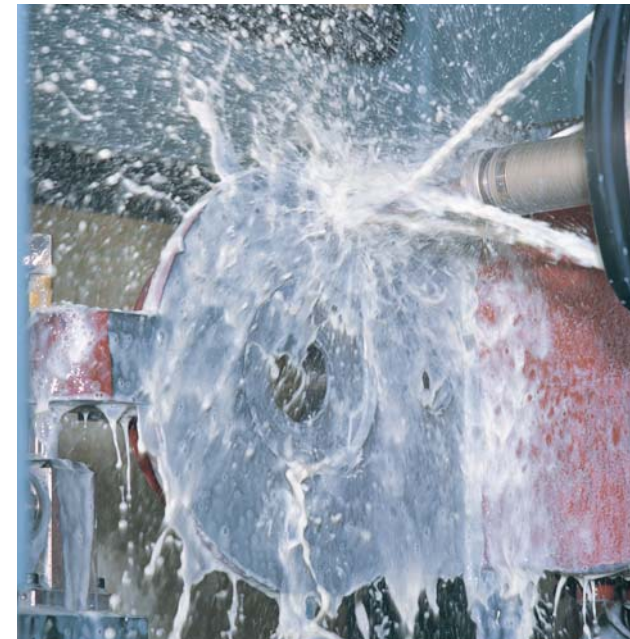

## CRAFTSMANSHIP – HAND-MADE FINISH PROCESS

### PRECISION PALLET POSITIONING

Pallets are located with precision accuracy by cone-shaped tapered pins and bushings, (6) sets for HN80D and (10) sets for HN100D. The precision cone positioning system insures long-term accuracy and reliability. The pallet clamping system adopts a stable clamber plate that provides super stability of the

pallet during heavy duty machining. Jets of air discharge from the tapered cones when the pallet is changed. This assures proper clamping and helps to clean the bottom of the bushing and the tapered surfaces. AC servo provides fast bidirectional table indexing. The large diameter curvic coupling provides extremely accurate positioning of the table.

### NIIGATA'S UNIQUE SPINDLE HEAD COOLING TECHNOLOGY

Niigata's unique cooling system minimizes thermal distortion during heavy load on the spindle. A large volume of temperature controlled spindle cooling oil is circulated around the spindle bearings and gear box. A thermo-couple temperature sensor is embodied into the machine base to control oil temperature to coordinate with the base of the machine.

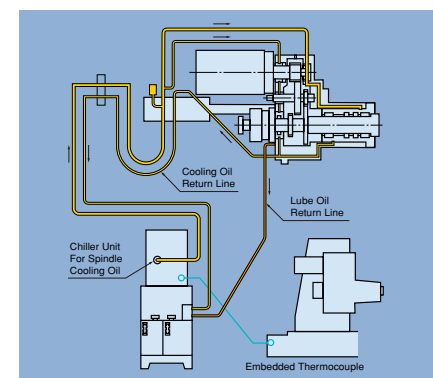
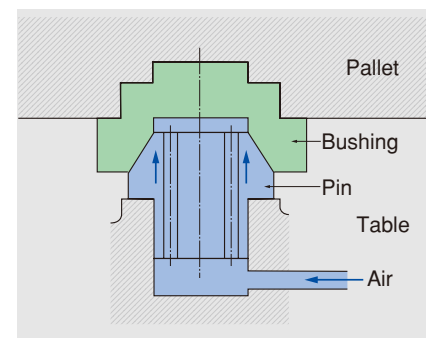

## EXACTING ACCURACY

- Accuracy of circular interpolation (end mill)  
Roundness(tolerance) 0.018mm {0.0007"}  
(Actual record) 0.0042mm {0.00017"}  
Material : FC20(cast iron)  
Processing dia :  $\phi$  250mm {9.84"}  
V=500m/min {1969ipm}  
F=200m/min(per tip 0.04mm) {7.87ipm(per tip 0.0016" ) }  
t=0.1mm {0.004" }

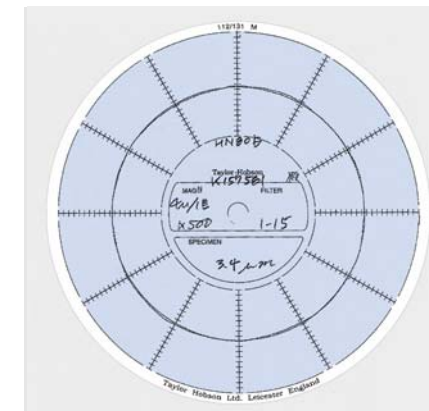

- Positioning accuracy  
Actual record 0.005mm {0.00020"}  
Material FC25(cast iron)  
Hole to hole 330mm {13"}  
Hole dia 40mm {1.575"}  
Hole depth 198mm {7.815"}  
Hole chamfer 1.5mm {0.059"}  
Hole chamfer angle 45°

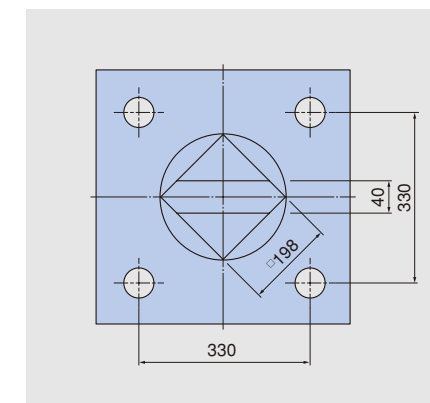

**SCALE FEEDBACK SYSTEM**  
HN100D Is equipped with optical scale feedback system (on X,Y,Z axis) as standard (available on HN80D as an option). This feature provides consistent long life dynamic machine accuracy.

## DESIGN DETAILS FOCUSED ON OPERATOR FRIENDLINESS



### CENTRALIZED OPERATOR CONSOLE

The control panel is strategically located at the most convenient position so the operator can easily monitor the work piece and machining operations, while utilizing the control functions. Hand held manual pulse generator is compact and light for operator-friendly handling.

### EXCELLENT ACCESSIBILITY TO THE WORK ZONE

Large sliding operator door allows easy and safe access to the machining area. A slanted ceiling of the enclosure minimizes coolant dripping on the operator.

### WORK SETUP IS SAFE AND EASY

The reliable rotary type pallet changer system accommodates large fixtures and work pieces. Niigata's solution is the walk-around platform, which allows easy set-up and operator safety.

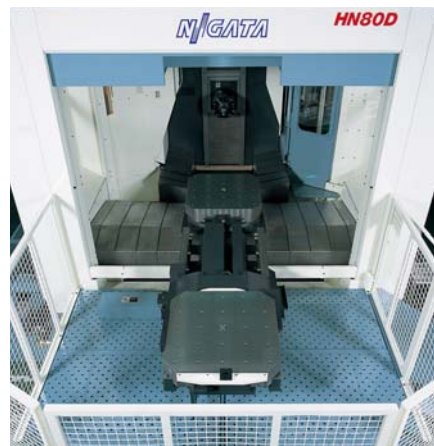

### SAFE AND CONVENIENT SET-UP OF TOOLING

The tool magazine is on the side of the machine, outside the chip enclosure, and away from the cutting area. This design permits easy accessibility for tool inspection and replacement.

Jog rotation of the tool magazine during automatic cycles facilitates tool inspection and changeover to maximize utilization. The load/unload station is located at a comfortable height for operator safety and ease.



## HIGH RELIABILITY AND EASE OF MAINTENANCE



### QUICK & EASY INSPECTION

Machine maintenance items such as a lubrication control unit are all centrally located at the rear of the machine for quick and easy inspection.

### OIL-AIR LUBRICATION SYSTEM

This system automatically assures constant lubrication to the spindle bearings to prevent premature failure (versus grease packed bearings which require periodic repacking).

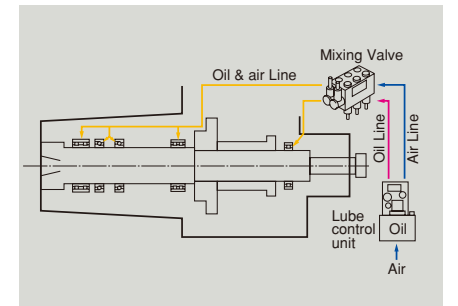

### FAST AND RELIABLE TOOL CHANGE SYSTEM

Tool magazine is driven by a servo motor for fast and reliable indexing. An electric servo motor positions the tool loader, insuring fast, smooth motion during a tool change. The tool inspection and loading/unloading during automatic operation are standard features. The tool magazine and the changer are free standing and are covered with a full enclosure. The ATC system is field expandable.

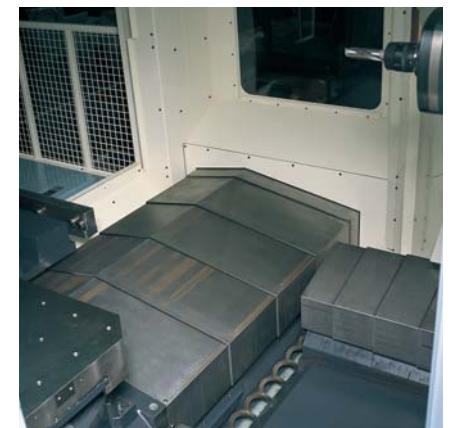

### EXCELLENT CHIP REMOVAL

Independent Z axis telescopic slide way covers and a chip scraper between the Z ways force the chips to drop into the large coil chip augers. Roof-shaped telescopic covers protect the X axis ways. These features provide automatic chip evacuation from the inside of machining area.

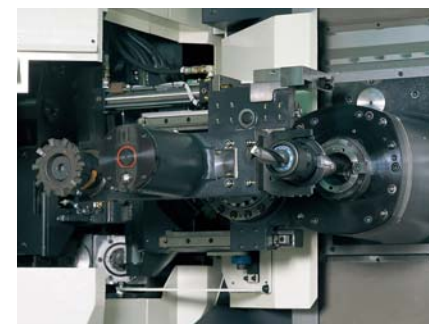
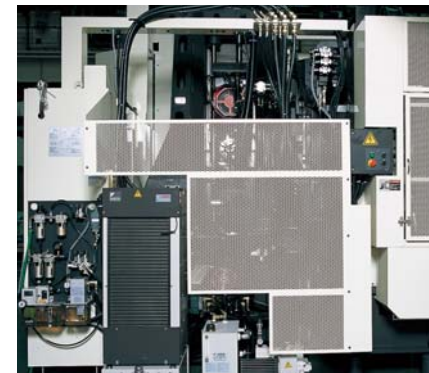
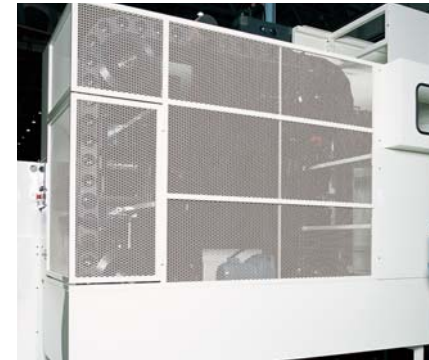

### THE FULLY ENCLOSED SPLASH GUARD

Total enclosure contains all fluids and chips in machine area. Operator comfort and safety are NIIGATA's continual theme.

# MAXIMUM UTILIZATION OF VALUABLE FLOOR SPACE — **HN80D**

# LARGEST WORK CUBE OF ANY MACHINE IN ITS CLASS — **HN80D**

**HN80D General View**

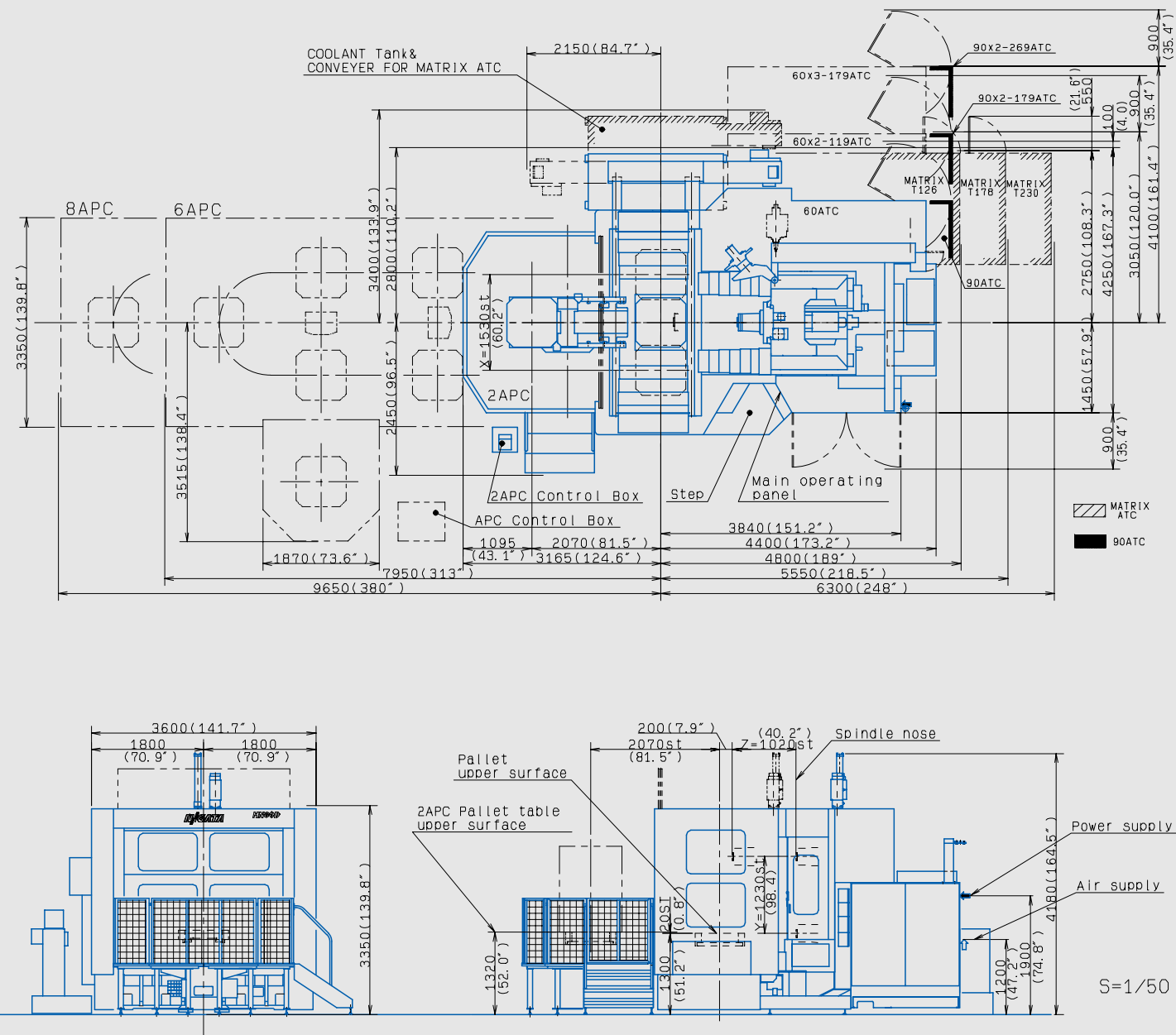

**Maximum work piece size**

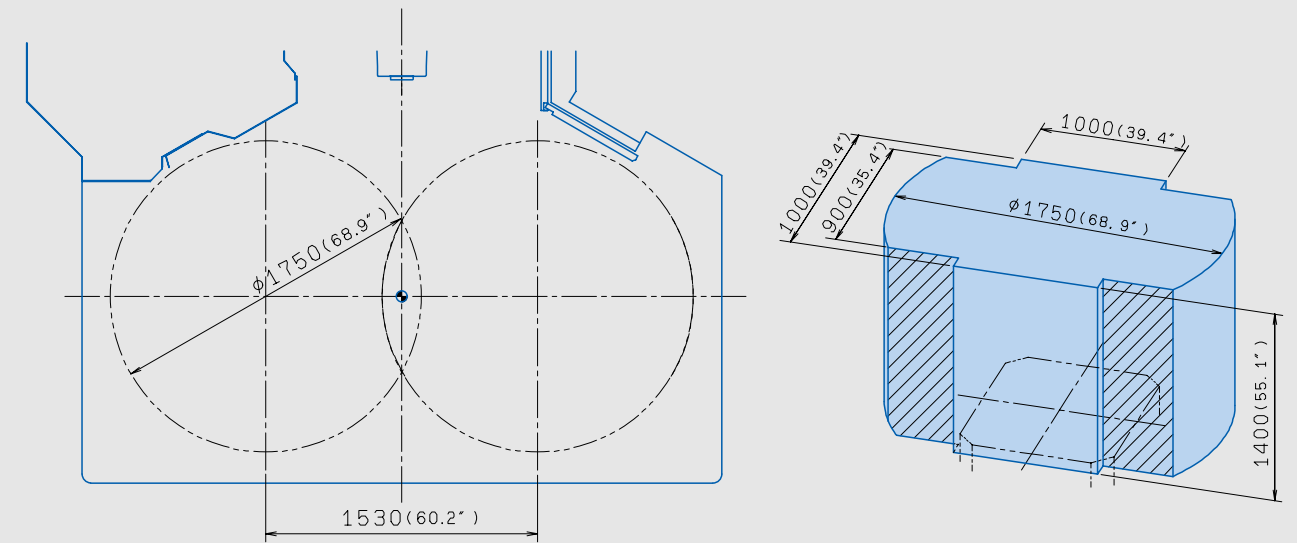

**Standard Pallet Top Surface**

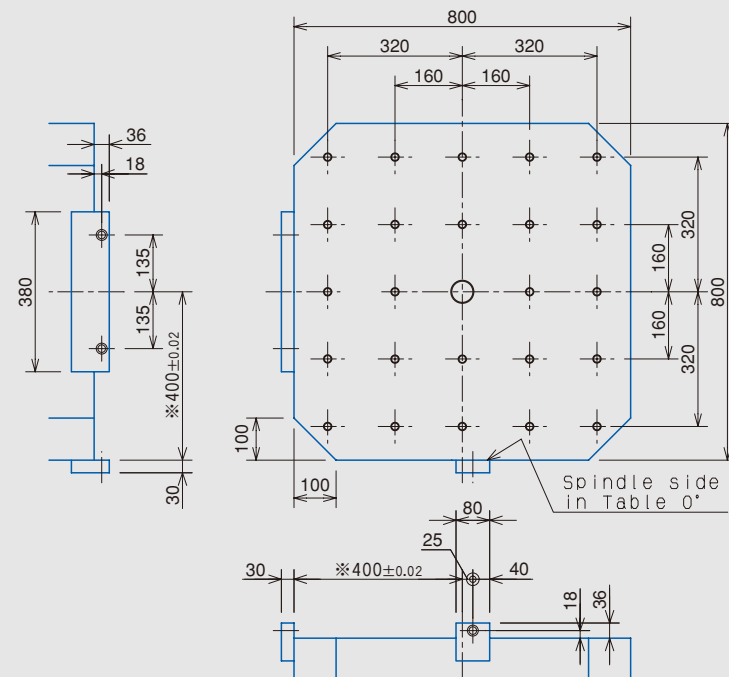



# WIDE RANGE OF OPTIONS TO ANSWER YOUR INDIVIDUAL MACHINING REQUIREMENTS



## STANDARD EQUIPMENT

- Automatic Tool Changer With 60ATC Tool Capacity
- 20-6000 RPM Two Gear Range Spindle
- Spindle Cooling Unit
- One Degree Indexing Table
- Rotary Type Twin Pallet Change System with Walk-Around Platform
- Front and Rear Spiral Chip Augers Built into the Bed
- Flood Coolant System
- Full Enclosure-Type Splash and Chip Guarding System
- Work Completion and Emergency Lamp
- Fanuc CNC System
- 10.4" Color LCD
- Rigid Tapping
- Spindle Load/Speed Meter display on CNC Screen
- Self Diagnostics Function
- Automatic Power-Off Device

## OPTIONAL FEATURES

### AXIS FEEDBACK SYSTEM

- Scale FeedBack System on XYZ Axes (Optical Scale Type) Standard on HN100D

### ATC MAGAZINE (Field Expandable)

- 90 Tool Magazine
- 119 Tool Magazine (60 x 2)
- 179 Tool Magazine (60 x 3 / 90 x 2)
- 239 Tool Magazine (60 x 4)
- Matrix Style ATC System (126 / 178 / 230)

### TABLES

- 0.001°K(NC Table) / 4th Axis Continuous
- 5 Axis Application (Table on Table)
- Increase of Max Load capacity (available on HN100D only with NC Table)
- Idle Pallet Rotation on 2APC (available on HN80D only)

### PALLET and PALLET CHANGER SYSTEM

- Carousel Type Multiple Pallet Changer 6/8/10/12 APC (only 6 APC for HN100D)
- Linear Pallet Magazine System with Niigata ICC System Controller
- Additional Pallet
- T-slotted pallet (Tapped Hole pattern with edge locator is Standard /Restriction of Max Load on Pallet may apply)

### COOLANT SYSTEM

- Spindle Center Through Coolant
- Spindle Flange Through Coolant
- Overhead Shower Coolant System
- Shower Coolant and Airblow Function

- Work piece Washing Gun
- Oversized Coolant Tank
- Coolant Low Level Sensing Device

### CHIP REMOVAL

- Hinge Type Lift-Up External

### Conveyor

- Lift-Up External Conveyor with Filtration System
- Chip Bucket with Caster and Handles ?????

### MONITORING FUNCTION

- Advanced Unmanned Monitoring System / NIIGATA MONITOR ACE
- Spindle Probe
- Table Probe
- Tool Breakage Detector LS-Z Type
- 4 Face Part Program Control Function

### SPINDLE

- BIG PLUS Spindle
- Facing Center Version (See page 20-21)
- Bar Spindle version (See page 22-23)

## OPTIONAL FEATURES

### MULTIPLE PALLET CHANGE SYSTEM

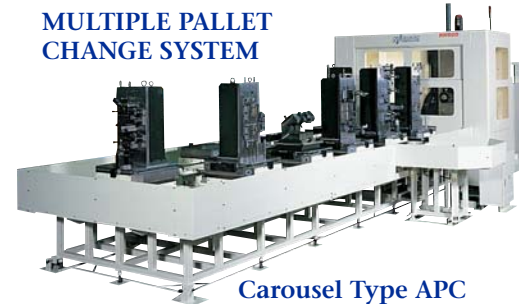

Carousel Type APC

### LINEAR PALLET MAGAZINE SYSTEM WITH NIIGATA ICC SYSTEM CONTROLLER



### MATRIX Type AUTOMATIC TOOL CHANGE SYSTEM

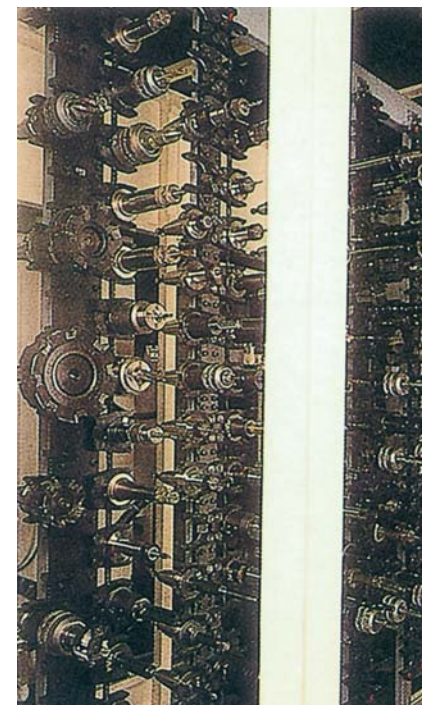

### TOOL MAGAZINE TYPE AUTOMATIC TOOL CHANGE SYSTEM

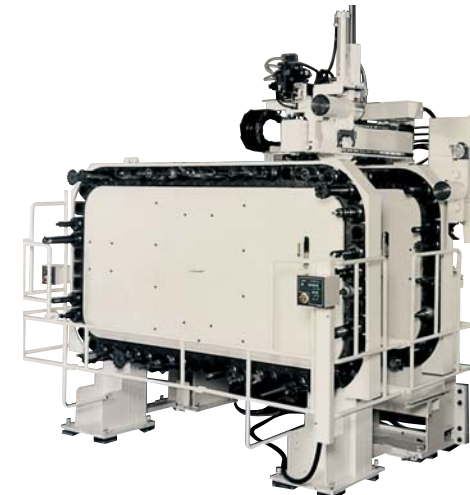

60+60 Tool Magazine Type

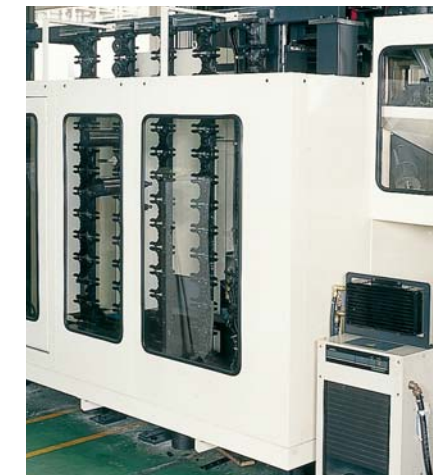

### HIGH PRESSURE TYPE COOLANT THROUGH SPINDLE SYSTEM

#### Coolant thru spindle center

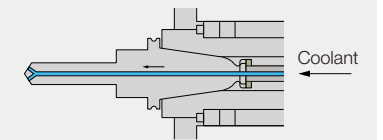

#### Coolant thru flange

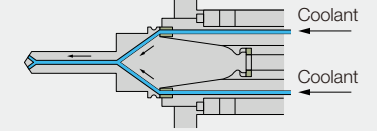

### ADVANCED UNMANNED MONITORING SYSTEM NIIGATA MONITOR ACE (NM24 Generation II)



### KEY FEATURES

- Display on machine operational screen: All main features shown on machine operational screen (Fanuc CNC control)
- Cutting monitor—Max Spindle load monitor / Adaptive Control / Axis load monitor / Feed rate monitor: Set the reference data of spindle load / Axis load and monitor the actual data during the machine run to minimize cutting Issues as well as machining of defective parts.
- Tool Life Monitor / Spare Tool Function:

- Set life time value on each tool and monitor the actual time used. The alarm occurs when the time of life reaches the set value. Automatic change of the tool to alternative tool is available when spare tool is ready.
- Automatic Continuous Machine Run: Automatically proceed to the next work piece after the monitoring system detects some alarm condition on current process.
- Tool Number Conversion: Eight (8) digits tool number is available as a standard function.

# THE VERSATILE HORIZONTAL FACING CENTER MODEL HN80D-FC/HN100D-FC

## Developed Based On NIIGATA's Heavy Duty Box Way Style

### HN80D/HN100D Horizontal Machining Center

#### INCREASE YOUR PRODUCTION BY MACHINING IN SINGLE SET-UP WITH NIIGATA'S HN80D/100D-FC FACING CENTER

Turning, facing, boring and milling capabilities are all combined in one machine for complete machining in single set-up.

Built-in, CNC-controlled boring and facing head utilize the versatility of combined turning operations with machining center operations. Single set-up approach for the machining of valve bodies, pump bodies, bearing housing, differential or axle housing, clutch housing, etc.

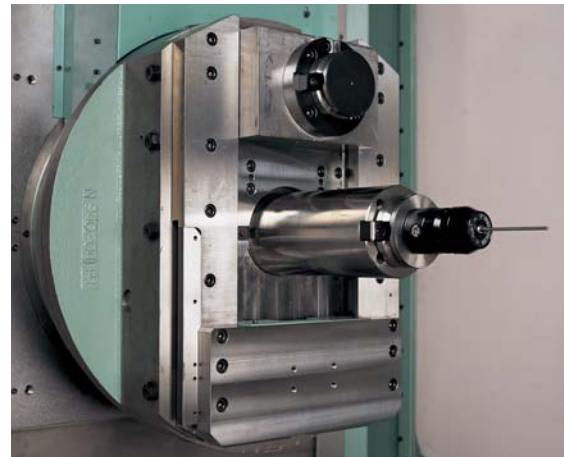

Probing

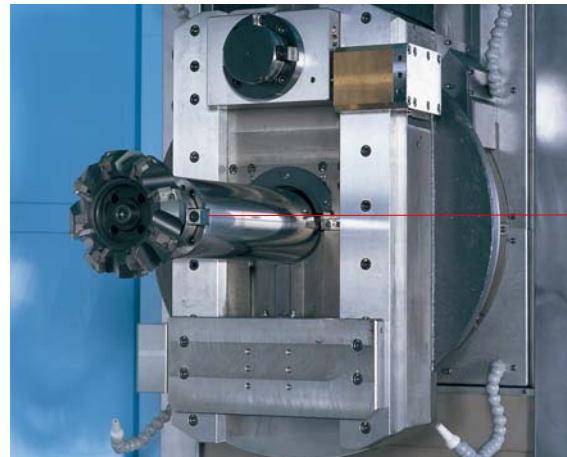

Milling Cutter In extended Bar

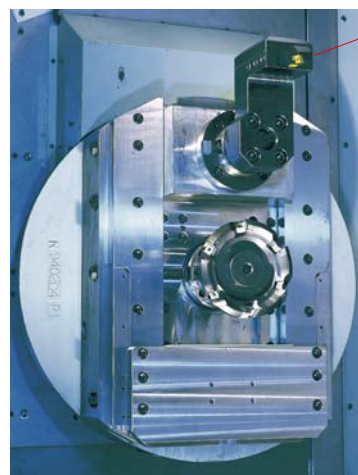
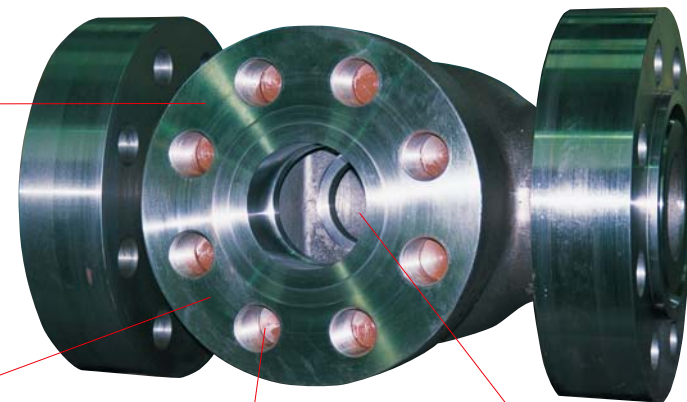

Turning and back facing the flange  
Grooving the flange face

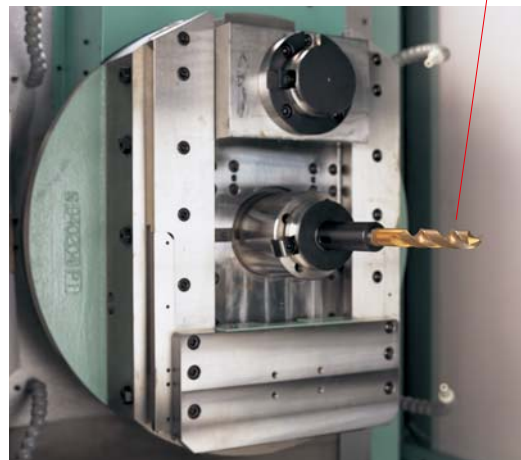

MATRIX Type AUTOMATIC TOOL



MATRIX Type AUTOMATIC TOOL

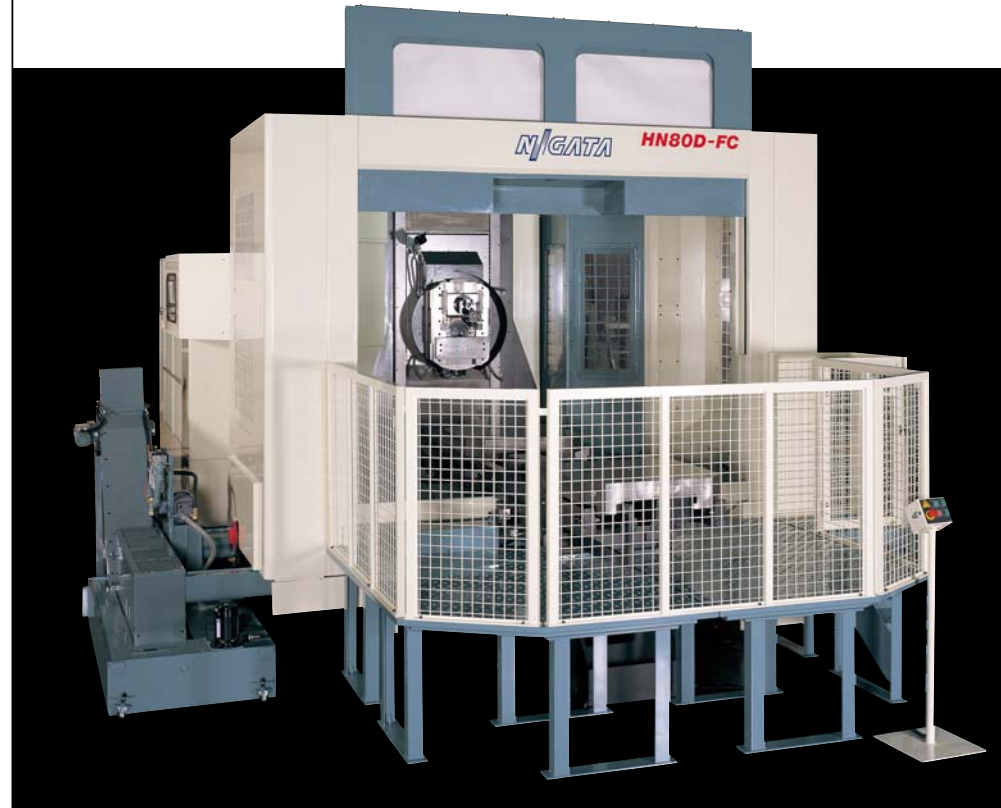

#### RIGID, WELL-BALANCED SPINDLE DESIGN MAXIMIZES PERFORMANCE

The HN80/100FC headstock with large diameter bearings support the facing head throughout the drive train. 130 mm {5.12"} diameter spindle quill is integral to the facing

head, and is fully supported as a W-axis, and is the largest of any machine in its class. The torque rating of 1,486 N·m {1,098 ft·lbs} makes this HN80/100FC one of the most rigid machines in the market. The extremely well balanced head stock and simplicity of design allows

ease of tradition machining operations, and rapid tool changing for turning applications. The spindle quill is retracted to the home position behind the facing head to eliminate interference.

#### AXIS TRAVEL

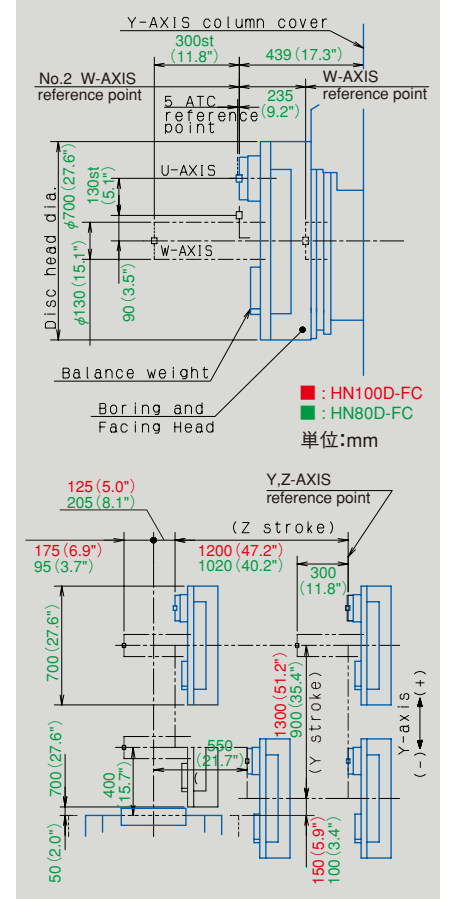

#### TURNING TOOL HOLDERS (U-AXIS)

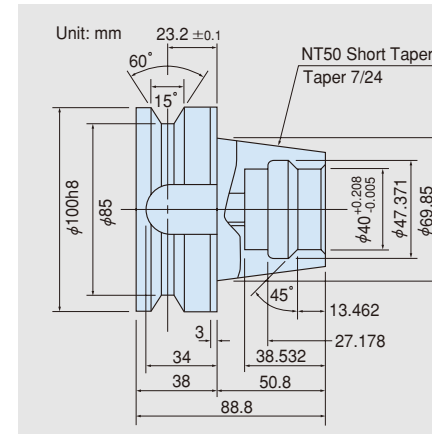

# THE HORIZONTAL BAR CENTER MODEL HN80D-BAR/HN100D-BAR

## Developed Based On NIIGATA's Heavy Duty Box Way Style

### HN80D/HN100D Horizontal Machining Center

#### BAR/QUILL CAPABILITY ON HORIZONTAL MACHINING CENTER

Niigata's HN80D and HN100D machining centers, always known for rugged, reliable performance, can be equipped with a Bar/Quill style spindle. The BAR versions bring long-sought improvements in performance and accuracy to the work traditionally done by horizontal boring mills.

(Medium carbon steel S45C) RIGID / HEAD STOCK

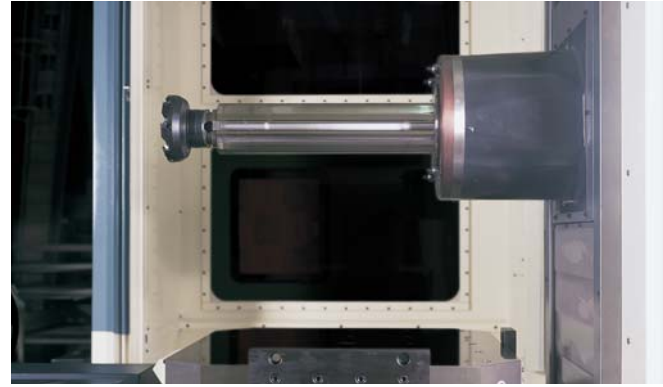

EXAMPLE OF HN80D-BAR's MACHINING PERFORMANCE (Medium carbon steel S45C)

#### RIGID / HEAD STOCK DESIGN

| Face mill                             |   |                      |                      |
|---------------------------------------|---|----------------------|----------------------|
| W axis extension                      | l | 55mm {2.2inches}     | 220mm {8.7inches}    |
| Cutting position from spindle surface | L | 160mm {6.3inches}    | 325mm {12.8inches}   |
| Cutting volume                        |   | 691cc/min{42cu.inch} | 605cc/min{37cu.inch} |
| Tooling diameter                      |   | 160mm {6.3inches}    | 160mm {6.3inches}    |
| Width of cut                          | B | 120mm {4.7inches}    | 120mm {4.7inches}    |
| Depth of cut                          |   | 8mm {0.32inches}     | 7mm {0.28inches}     |
| Spindle speed                         |   | 330min-1             | 300min-1             |
| Feed rate                             |   | 720mm/min {28.3ipm}  | 720mm/min {28.3ipm}  |
| Boring                                |   |                      |                      |
| W axis extension                      | l | 365mm {14.4inches}   | 535mm {21inches}     |
| Cutting position from spindle surface | L | 685mm {27inches}     | 855mm {33.7inches}   |
| Cutting volume                        |   | 272cc/min{17cu.inch} | 188cc/min{12cu.inch} |
| Boring diameter                       | B | 240mm {9.4inches}    | 228mm {9.0inches}    |
| Depth of cut                          | t | 7mm {0.28inches}     | 6mm {0.24inches}     |
| Spindle speed                         |   | 150min-1             | 168min-1             |
| Feed rate                             |   | 53mm/min {2.1ipm}    | 45mm/min {1.8ipm}    |

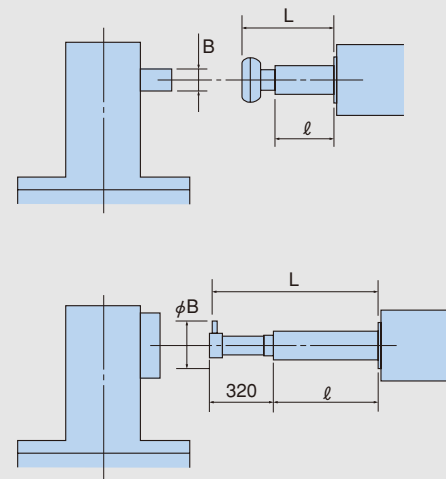

#### RIGID / HEAD STOCK DESIGN

The BAR versions bring long-sought after improvements in performance and accuracy to the work traditionally done by horizontal boring mills.

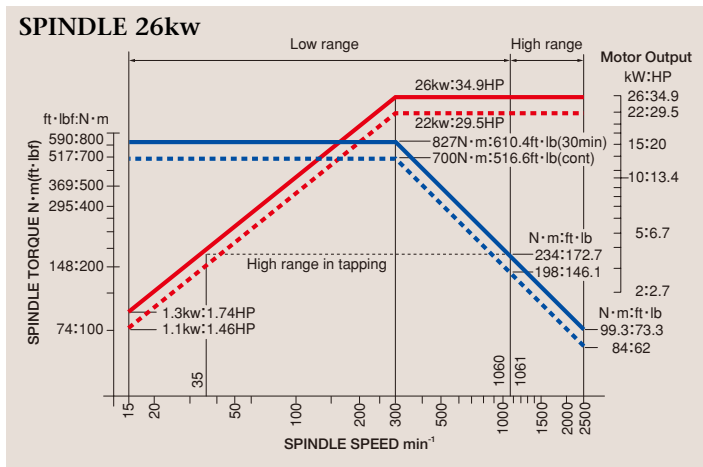
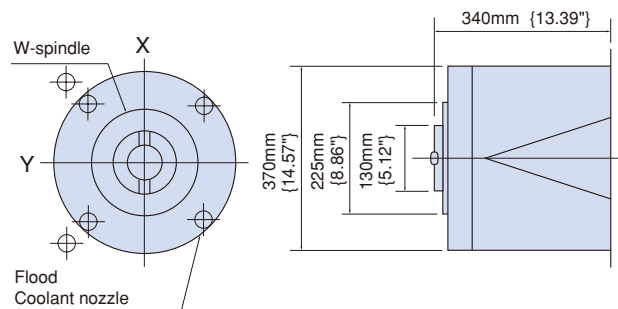

#### SUPERIOR FEATURES OVER THE TRADITIONAL BORING MILLS

- RIGID SPINDLE SNOOT  
Reduces the need to extend the quill to reach the part; provides a high radial load capability for heavy milling cuts.
- CENTER-MOUNTED SPINDLE  
Eliminates the column twist of side-mounted spindle.
- COLUMN FEED  
Superior accuracy and rigidity vs. table-fed machines, with compound slides (stacked X and Z axes).
- FASTER TRAVERSE AND FEED SPEEDS  
Higher productivity, more parts per shift, faster ROI vs. horizontal boring mills.
- ERGONOMICALLY SUPERIOR  
A full enclosure is standard, along with automatic tool changer and pallet changer to maximize the performance and productivity of your operation.
- TRUE COOLANT THRU THE SPINDLE  
-Better cutting conditions.  
-Longer tool life.  
-Superior chip removal.  
-Not available from some competitors.  
-Special tool holders are not required.

#### HN-80D/100D BAR MACHINE

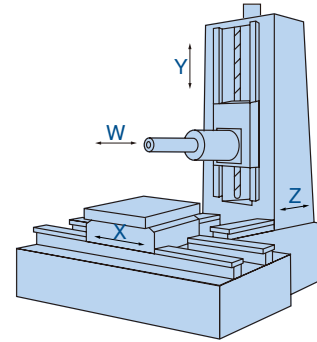

#### TYPICAL BORING MILL

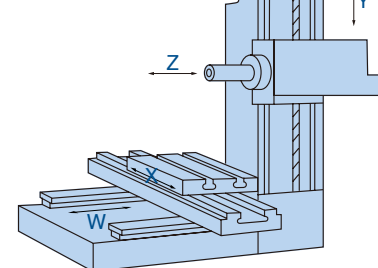

#### SPINDLE DISTANCES

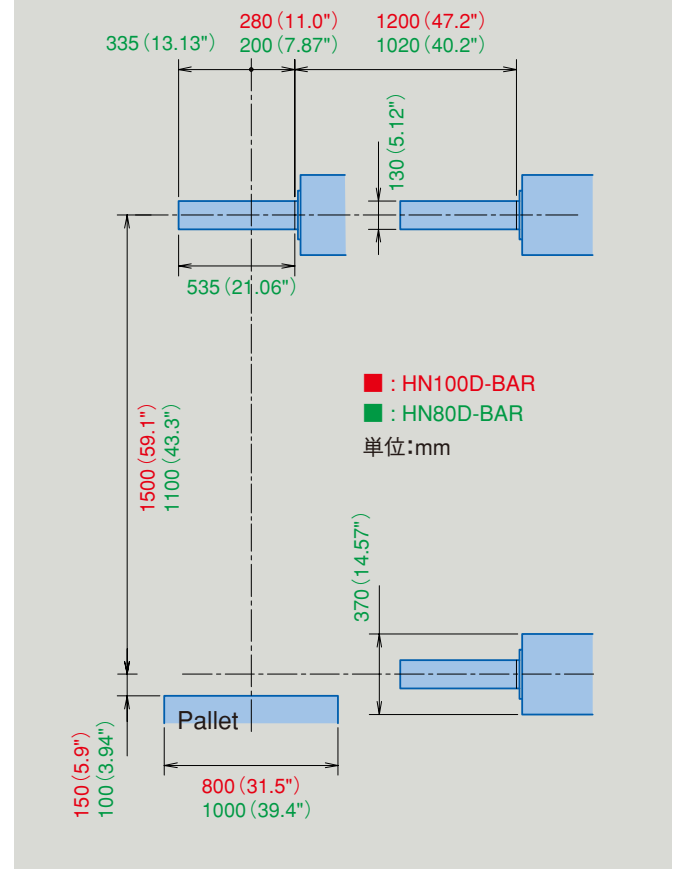

# MACHINE SPECIFICATIONS



| ITEM                           | HN80D                                 |                     | HN100D              |                     |                     |
|--------------------------------|---------------------------------------|---------------------|---------------------|---------------------|---------------------|
|                                | Metric                                | Inch                | Metric              | Inch                |                     |
| TRAVEL                         | X axis travel (longitudinal table)    | 1530 mm             | 60.2 "              | 2030 mm             | 79.92 "             |
|                                | Y axis travel (vertical head)         | 1230 mm             | 48.4 "              | 1650 mm             | 64.96 "             |
|                                | Z axis travel (column in & out)       | 1020 mm             | 40.2 "              | 1200 mm             | 47.24 "             |
|                                | Spindle center line to pallet surface | 0 ~ 1230            | 0 ~ 48.4 "          | 50 ~ 1700 mm        | 1.96 ~ 66.92 "      |
|                                | Spindle nose to table center line     | 200 ~ 1220          | 7.9 ~ 48.0 "        | 280 ~ 1480 mm       | 11.0 ~ 58.24 "      |
| TABLE                          | Table working surface                 | 800 × 800 mm        | 31.5 × 31.5 "       | 1000 × 1000 mm      | 39.37 × 39.37 "     |
|                                | Table increments                      | 1° [0.001°]         | 1° [0.001°]         | 1° [0.001°]         | 1° [0.001°]         |
|                                | Maximum mass on pallet                | 2500 kg             | 5500 lbs            | 3500 kg             | 7700 lbs            |
| SPINDLE                        | Spindle drive motor                   | AC 37/30 Kw         | AC 50 / 40 HP       | AC 37/30 Kw         | AC 50 / 40 HP       |
|                                | Spindle speeds                        | 6000 min-1          | 6000 rpm            | 6000 min-1          | 6000 rpm            |
|                                | Spindle max. torque                   | 1200 N·m            | 886 ft.lbs          | 1200 N·m            | 886 ft.lbs          |
|                                | Spindle taper                         | No.50               | No.50               | No.50               | No.50               |
| FEEDRATE                       | Rapid traverse X axis                 | 30 m/min            | 1181 ipm            | 20 m/min            | 787 ipm             |
|                                | Y axis                                | 30 m/min            | 1181 ipm            | 20 m/min            | 787 ipm             |
|                                | Z axis                                | 30 m/min            | 1181 ipm            | 20 m/min            | 787 ipm             |
|                                | Cutting X - Y - Z                     | 1 ~ 15000 mm/min    | 0.04 ~ 590 ipm      | 1 ~ 6000 mm/min     | 0.04 ~ 236 ipm      |
|                                | Table index speed / 1° table          | 12 min-1            | 12 rpm              | 5 min-1             | 5 rpm               |
|                                | NC table                              | 11.1 min-1          | 11.1 rpm            | 4 min-1             | 4 rpm               |
| 5ton NC table                  | N / A                                 | N / A               | 2 min-1             | 2 rpm               |                     |
| AUTOMATIC TOOL CHANGER (ATC)   | Tool magazine capacity                | 60 [90/119/179/239] | 60 [90/119/179/239] | 60 [90/119/179/239] | 60 [90/119/179/239] |
|                                | Tool selection                        | Short cut random    | Short cut random    | Short cut random    | Short cut random    |
|                                | Tool shank                            | BT 50               | CT50                | BT 50               | CT50                |
|                                | Maximum tool length                   | 610 mm              | 24 "                | 610 mm              | 24 "                |
|                                | Maximum milling cutter dia.           | 120 mm              | 4.7 "               | 120 mm              | 4.7 "               |
|                                | Ditto adjacent pockets empty          | 230 mm              | 9.1 "               | 230 mm              | 9.1 "               |
|                                | Maximum tool mass (weight)            | 30kg [35kg]         | 66 lbs [77 lbs]     | 30kg [35kg]         | 66 lbs [77 lbs]     |
|                                | Tool change time (tool to tool)       | 6.5 s               | 6.5 sec.            | 6.5 s               | 6.5 sec.            |
| AUTOMATIC PALLET CHANGER (APC) | Type                                  | Rotary shuttle      | Rotary shuttle      | Rotary shuttle      | Rotary shuttle      |
|                                | Pallet change time                    | 53 s                | 53 sec.             | 75 s                | 75 sec.             |
|                                | 5ton                                  | N / A               | N / A               | 120 s               | 120 sec.            |
|                                | Number of pallets                     | 2                   | 2                   | 2                   | 2                   |
| ACCURACY                       | Positioning / full stroke X-Y-Z       | ± 0.004 mm          | ± 0.00016 "         | N / A               | N / A               |
|                                | Ditto with scales X-Y-Z               | ± 0.003 mm          | ± 0.00012 "         | ± 0.004 mm          | ± 0.00016 "         |
|                                | Repeatability X-Y-Z                   | ± 0.002 mm          | ± 0.00008 "         | N / A               | N / A               |
|                                | Ditto with scales X-Y-Z               | ± 0.0015 mm         | ± 0.00006 "         | ± 0.0015 mm         | ± 0.00006 "         |
|                                | Table index 360 position              | ± 3 "               | ± 3 "               | ± 3 "               | ± 3 "               |
| GENERAL                        | Machine weight approx.                | 25000 kg            | 55000 lbs           | 30000 kg            | 66000 lbs           |
|                                | Machine space W / D                   | 4561 / 7565 mm      | 179.6 / 297.8 "     | 5580 / 9950 mm      | 220 / 392 "         |
|                                | Ditto H                               | 4180 mm             | 164.6 "             | 4850 mm             | 190.9 "             |
|                                | Floor to table surface                | 1300 mm             | 51.2 "              | 1290 mm             | 50.8 "              |
|                                | Power                                 | 95 KVA              | 95 KVA              | 100kVA              | 100kVA              |
|                                | Control                               | Fanuc 18iM (16iM)   | Fanuc 18iM (16iM)   | Fanuc 18iM (16iM)   | Fanuc 18iM (16iM)   |

| ITEM                           | HN80D-FC                              |                       | HN100D-FC           |                     |                     |
|--------------------------------|---------------------------------------|-----------------------|---------------------|---------------------|---------------------|
|                                | Metric                                | Inch                  | Metric              | Inch                |                     |
| TRAVEL                         | X axis travel (longitudinal table)    | 1530 mm               | 60.2 "              | 2030 mm             | 79.9 "              |
|                                | Y axis travel (vertical head)         | 900 mm                | 35.4 "              | 1300 mm             | 51.1 "              |
|                                | Z axis travel (column in & out)       | 1020 mm               | 40.2 "              | 1200 mm             | 47.24 "             |
|                                | Spindle center line to pallet surface | 100 ~ 1000            | 3.9 ~ 39.4 "        | 150 ~ 1450 mm       | 5.9 ~ 57.0 "        |
|                                | Spindle nose to table center line     | 125 ~ 1145            | 4.9 ~ 45.1 "        | 205 ~ 1405 mm       | 8.0 ~ 55.3 "        |
|                                | W axis travel (spindle quill)         | 300 mm                | 11.8 "              | 300 mm              | 11.8 "              |
|                                | U axis travel (facing slide)          | 130 mm                | 5.1 "               | 130 mm              | 5.1 "               |
|                                | TABLE                                 | Table working surface | 800 × 800 mm        | 31.5 × 31.5 "       | 1000 × 1000 mm      |
| Table increments               |                                       | 1° [0.001°]           | 1° [0.001°]         | 1° [0.001°]         | 1° [0.001°]         |
| Maximum mass on pallet         |                                       | 2500 kg               | 5500 lbs            | 3500 kg             | 7700 lbs            |
| SPINDLE                        | Spindle drive motor                   | AC 26/22 Kw           | AC 35 / 30 HP       | AC 26/22 Kw         | AC 35 / 30 HP       |
|                                | Spindle speeds                        | 1500 min-1            | 1500 rpm            | 1500 min-1          | 1500 rpm            |
|                                | Facing head speeds                    | 600 min-1             | 600 rpm             | 600 min-1           | 600 rpm             |
|                                | Spindle max. torque                   | 659.5 N·m             | 487 ft.lbs          | 659.5 N·m           | 487 ft.lbs          |
|                                | Facing head max. torque               | 1486 N·m              | 1097 ft.lbs         | 1486 N·m            | 1097 ft.lbs         |
|                                | Spindle quill dia.                    | 130 mm                | 5.1 "               | 130 mm              | 5.1 "               |
|                                | Spindle taper                         | No.50                 | No.50               | No.50               | No.50               |
|                                | Facing head dia.                      | 700 mm                | 27.6 "              | 700 mm              | 27.6 "              |
| FEEDRATE                       | Rapid traverse X axis                 | 30 m/min              | 1181 ipm            | 20 m/min            | 787 ipm             |
|                                | Y axis                                | 15 m/min              | 591 ipm             | 15 m/min            | 591 ipm             |
|                                | Z axis                                | 20 m/min              | 787 ipm             | 15 m/min            | 591 ipm             |
|                                | U-W axis                              | 5 m/min               | 197 ipm             | 5 m/min             | 197 ipm             |
|                                | Cutting X axis                        | 1 ~ 15000 mm/min      | 0.04 ~ 590 ipm      | 1 ~ 6000 mm/min     | 0.04 ~ 236 ipm      |
|                                | Y-Z axis                              | 1 ~ 10000 mm/min      | 0.04 ~ 394 ipm      | 1 ~ 6000 mm/min     | 0.04 ~ 236 ipm      |
| U-W axis                       | 1 ~ 4000 mm/min                       | 0.04 ~ 157 ipm        | 1 ~ 4000 mm/min     | 0.04 ~ 157 ipm      |                     |
| Table index speed / 1° table   | NC table                              | 11.1 min-1            | 11.1 rpm            | 4 min-1             | 4 rpm               |
|                                | 5ton NC table                         | N / A                 | N / A               | 2 min-1             | 2 rpm               |
|                                |                                       |                       |                     |                     |                     |
| AUTOMATIC TOOL CHANGER (ATC)   | Tool magazine capacity                | 60 [90/119/179/239]   | 60 [90/119/179/239] | 60 [90/119/179/239] | 60 [90/119/179/239] |
|                                | Tool selection                        | Short cut random      | Short cut random    | Short cut random    | Short cut random    |
|                                | Tool shank                            | BT 50                 | CT50                | BT 50               | CT50                |
|                                | Maximum tool length                   | 550 mm                | 21.7 "              | 550 mm              | 21.7 "              |
|                                | Maximum milling cutter dia.           | 120 mm                | 4.7 "               | 120 mm              | 4.7 "               |
|                                | Ditto adjacent pockets empty          | 230 mm                | 9.1 "               | 230 mm              | 9.1 "               |
| AUTOMATIC PALLET CHANGER (APC) | Maximum tool mass (weight)            | 30kg                  | 66 lbs              | 30kg                | 66 lbs              |
|                                | Tool change time (tool to tool)       | 11.8 s                | 11.8 sec.           | 11.8 s              | 11.8 sec.           |
|                                | Type                                  | Rotary shuttle        | Rotary shuttle      | Rotary shuttle      | Rotary shuttle      |
| ACCURACY                       | Positioning / full stroke X-Y-Z       | ± 0.004 mm            | ± 0.00016 "         | N / A               | N / A               |
|                                | Ditto with scales X-Y-Z               | ± 0.003 mm            | ± 0.00012 "         | ± 0.004 mm          | ± 0.00016 "         |
| GENERAL                        | Repeatability X-Y-Z                   | ± 0.002 mm            | ± 0.00008 "         | N / A               | N / A               |
|                                | Ditto with scales X-Y-Z               | ± 0.0015 mm           | ± 0.00006 "         | ± 0.0015 mm         | ± 0.00006 "         |
|                                | Table index 360 position              | ± 3 "                 | ± 3 "               | ± 3 "               | ± 3 "               |
|                                |                                       |                       |                     |                     |                     |
| GENERAL                        | Machine weight approx.                | 26000 kg              | 57200 lbs           | 31000 kg            | 68200 lbs           |
|                                | Machine space W / D                   | 4561 / 7565 mm        | 179.6 / 297.8 "     | 5580 / 9950 mm      | 220 / 392 "         |
|                                | Ditto H                               | 4180 mm               | 164.6 "             | 4850 mm             | 190.9 "             |
|                                | Floor to table surface                | 1300 mm               | 51.2 "              | 1290 mm             | 50.8 "              |
|                                | Power                                 | 95 KVA                | 95 KVA              | 95 KVA              | 95 KVA              |
|                                | Control                               | Fanuc 18iM (16iM)     | Fanuc 18iM (16iM)   | Fanuc 18iM (16iM)   | Fanuc 18iM (16iM)   |

| ITEM                           |                                       | HN80D-BAR           |                     | HN100D-BAR          |                     |
|--------------------------------|---------------------------------------|---------------------|---------------------|---------------------|---------------------|
|                                |                                       | Metric              | Inch                | Metric              | Inch                |
| TRAVEL                         | X axis travel (longitudinal table)    | 1530 mm             | 60.2 "              | 2030 mm             | 79.9 "              |
|                                | Y axis travel (vertical head)         | 1100 mm             | 43.3 "              | 1500 mm             | 59.06 "             |
|                                | Z axis travel (column in & out)       | 1020 mm             | 40.2 "              | 1200 mm             | 47.24 "             |
|                                | W axis travel                         | 535 mm              | 21.1 "              | 535 mm              | 21.1 "              |
|                                | Spindle center line to pallet surface | 100 ~ 1200          | 3.9 ~ 47.2 "        | 150 ~ 1650 mm       | 5.9 ~ 64.96 "       |
|                                | Spindle nose to table center line     | 200 ~ 1220          | 7.9 ~ 48.0 "        | 280 ~ 1480 mm       | 11.0 ~ 58.3 "       |
| TABLE                          | Table working surface                 | 800 × 800 mm        | 31.5 × 31.5 "       | 1000 × 1000 mm      | 39.4 × 39.4 "       |
|                                | Table increments                      | 1° [0.001°]         | 1° [0.001°]         | 1° [0.001°]         | 1° [0.001°]         |
|                                | Maximum mass on pallet                | 2500 kg             | 5500 lbs            | 3500 kg             | 7700 lbs            |
|                                |                                       |                     |                     |                     |                     |
| SPINDLE                        | Spindle drive motor                   | AC 26/22 Kw         | AC 35 / 30 HP       | AC 26/22 Kw         | AC 35 / 30 HP       |
|                                | Spindle speeds                        | 2500 min-1          | 2500 rpm            | 2500 min-1          | 2500 rpm            |
|                                | Spindle max. torque                   | 827 N·m             | 610 ft.lbs          | 827 N·m             | 610 ft.lbs          |
|                                | Spindle taper                         | No.50               | No.50               | No.50               | No.50               |
| FEEDRATE                       | Rapid traverse X axis                 | 30 m/min            | 1181 ipm            | 20 m/min            | 787 ipm             |
|                                | Y axis                                | 20 m/min            | 787 ipm             | 20 m/min            | 787 ipm             |
|                                | Z axis                                | 20 m/min            | 787 ipm             | 20 m/min            | 787 ipm             |
|                                | W axis                                | 5 m/min             | 197 ipm             | 5 m/min             | 197 ipm             |
|                                | Cutting X axis                        | 1 ~ 15000 mm/min    | 0.04 ~ 590 ipm      | 1 ~ 6000 mm/min     | 0.04 ~ 236 ipm      |
|                                | Y-Z axis                              | 1 ~ 10000 mm/min    | 0.04 ~ 394 ipm      | 1 ~ 6000 mm/min     | 0.04 ~ 236 ipm      |
|                                | W axis                                | 1 ~ 4000 mm/min     | 0.04 ~ 157 ipm      | 1 ~ 4000 mm/min     | 0.04 ~ 157 ipm      |
|                                | Table index speed / 1° table          | 12 min-1            | 12 rpm              | 5 min-1             | 5 rpm               |
|                                | NC table                              | 11.1 min-1          | 11.1 rpm            | 4 min-1             | 4 rpm               |
|                                | Ston NC table                         | N / A               | N / A               | 2 min-1             | 2 rpm               |
| AUTOMATIC TOOL CHANGER (ATC)   | Tool magazine capacity                | 60 [90/119/179/239] | 60 [90/119/179/239] | 60 [90/119/179/239] | 60 [90/119/179/239] |
|                                | Tool selection                        | Short cut random    | Short cut random    | Short cut random    | Short cut random    |
|                                | Tool shank                            | BT 50               | CT50                | BT 50               | CT50                |
|                                | Maximum tool length                   | 610 mm              | 24 "                | 610 mm              | 24 "                |
|                                | Maximum milling cutter dia.           | 120 mm              | 4.7 "               | 120 mm              | 4.7 "               |
|                                | Ditto adjacent pockets empty          | 230 mm              | 9.1 "               | 230 mm              | 9.1 "               |
|                                | Maximum tool mass (weight)            | 30kg                | 66 lbs              | 30kg                | 66 lbs              |
|                                | Tool change time (tool to tool)       | 11.8 s              | 11.8 sec.           | 11.8 s              | 11.8 sec.           |
| AUTOMATIC PALLET CHANGER (APC) | Type                                  | Rotary shuttle      | Rotary shuttle      | Rotary shuttle      | Rotary shuttle      |
|                                | Pallet change time                    | 53 s                | 53 sec.             | 75 s                | 75 sec.             |
| ACCURACY                       | Positioning / full stroke X-Y-Z       | ± 0.004 mm          | ± 0.00016 "         | N / A               | N / A               |
|                                | Ditto with scales X-Y-Z               | ± 0.003 mm          | ± 0.00012 "         | ± 0.004 mm          | ± 0.00016 "         |
| GENERAL                        | Repeatability X-Y-Z                   | ± 0.002 mm          | ± 0.00008 "         | N / A               | N / A               |
|                                | Ditto with scales X-Y-Z               | ± 0.0015 mm         | ± 0.00006 "         | ± 0.0015 mm         | ± 0.00006 "         |
|                                | Table index 360 position              | ± 3 "               | ± 3 "               | ± 3 "               | ± 3 "               |
|                                | Machine weight approx.                | 25500 kg            | 56100 lbs           | 30500 kg            | 67100 lbs           |
| GENERAL                        | Machine space W / D                   | 4561 / 7565 mm      | 179.6 / 297.8 "     | 5580 / 9950 mm      | 220 / 392 "         |
|                                | Ditto H                               | 4180 mm             | 164.6 "             | 4850 mm             | 190.9 "             |
|                                | Floor to table surface                | 1300 mm             | 51.2 "              | 1290 mm             | 50.8 "              |
|                                | Power                                 | 95 KVA              | 95 KVA              | 95 KVA              | 95 KVA              |
|                                | Control                               | Fanuc 18iM (16iM)   | Fanuc 18iM (16iM)   | Fanuc 18iM (16iM)   | Fanuc 18iM (16iM)   |



# HN-D

**HN80D / HN100D** HN80D-FC / HN100D-FC  
HN80D-BAR / HN100D-BAR

**NEW MODELS** — HEAVY DUTY BOXWAY STYLE Horizontal Machining Centers



A World Leader of Horizontal Machining Centers

## NIIGATA MACHINE TECHNO CO., LTD.

1300, Okayama, Niigata-city 950 - 0821, Japan  
Phone : +81-25-270-9011 Fax : +81-25-272-0291  
http://www.n-mtec.co.jp



### TOKYO OFFICE

1-2, Sotokanda 5-chome, Chiyoda-ku, Tokyo 101-0021, Japan  
Phone : +81-3-5807-5460 Fax : +81-3-5807-5419

### SNK AMERICA, INC. - NIIGATA Product Group

1800 Howard Street, Elk Grove Village, IL 60007 USA  
Phone : +1(847)364-0801 Fax: +1(847)364-4363

Products specifications and machine appearance are subject to change without notice.  
All inch tables are converted from metric measurements.

2006.3.1000.SAN

**NIIGATA MACHINE TECHNO CO., LTD.**

Niigata, Japan